



---

# AQT-JBP SERIES

---

## SELF PRIMING JET BOOSTER PUMP

---



**Aquatrol JBP Series Jet Booster Pumps** are a perfect choice for boosting water pressure in residential, commercial and light industrial applications where low or inadequate water pressure exists. They are ideal for boosting pressure in shallow well applications where the water level is less than 29.5 feet deep.

- 0.5, 0.75, 1 and 1.5 HP
- 69.6 psi maximum pressure
- Shallow Well Pumps up to a depth of 25 ft.
- For Domestic Water Supply or Boosting Applications
- Compact and reliable design - Trouble-Free Operation
- Easy To Install, Easy To Use, Quiet Operation
- Weatherproof Material – Can Be Placed Outdoors
- Perfect For Homes, Cottages, Farms and Greenhouses

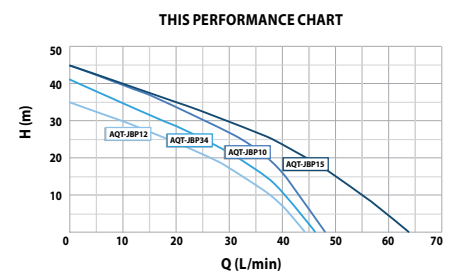

*This Performance Test is at n=2850 r/min*



# AQT-JBP SERIES

## SELF PRIMING JET BOOSTER PUMP

### JET BOOSTER PUMP SPECIFICATIONS

- VOLTAGE: 110V or 220V
- HERTZ: 50/60 Hz
- DISCHARGE SIZE: 1" FNPT
- MAX. SUCTION HEAD: 29.5 ft (9 m)
- LIQUID TEMPERATURE RANGE: 32 °F - 113 °F (0 °C - 40 °C)
- AQT-JBP12 WEIGHT: 17.6 lbs (8 kgs)
- AQT-JBP34, AQT-JBP10, AQT-JBP15 WEIGHT: 21 lbs (9.5 kgs)

### MATERIALS OF CONSTRUCTION

- PUMP BODY: Stainless Steel
- GUIDE PLATE: Reinforced Plastic
- IMPELLER: Polyphenylene Oxide (PPO)
- MECHANICAL SEAL: NBR, SS304, Ceramic and Carbon

### CHEMICAL COMPATIBILITY

**CAUTION!**  
The Self Priming Jet Booster Pump should ONLY be used to pump water.

**DANGER!**  
Do not pump flammable or explosive liquids such as oil, gasoline, kerosene, ethanol, etc. Do not use in the presence of flammable or explosive vapors. Using this pump with or near flammable liquids can cause an explosion or fire, resulting in property damage, serious personal injury, and/or death.

Use of different liquids is considered improper and can represent a danger to the user and equipment. Improper liquids can damage the pump material can damage the pump or the operator.

*Aquatrol will not be held responsible for damage deriving from improper use of the pump.*

PERFORMANCE								
PART #	HP	GPM @ TOTAL DISCHARGE PRESSURE OF 40 PSI					MAXIMUM PRESSURE	
		0 ft	5 ft	10 ft	15 ft	20 ft		25 ft
AQT-JBP12	0.5	10.6	10.3	10.04	9.77	9.51	9.25	50.8 psi (3.5 bar)
AQT-JBP34	0.75	12.1	12.02	11.62	11.36	11.23	10.96	58.0 psi (4 bar)
AQT-JBP10	1.0	13.2	13	12.81	12.55	12.42	12.15	65.3 psi (4.5 bar)
AQT-JBP15	1.5	15.8	15.59	15.19	14.79	14.45	14.13	69.6 psi (4.8 bar)

### JET BOOSTER PUMP DIMENSIONS

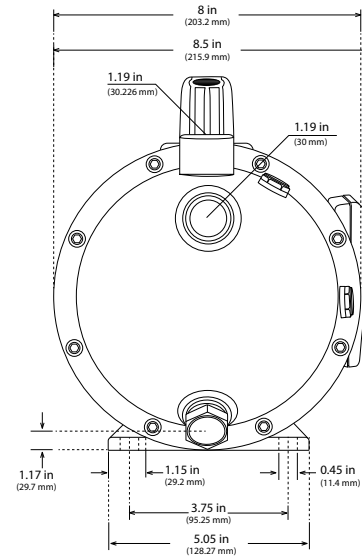
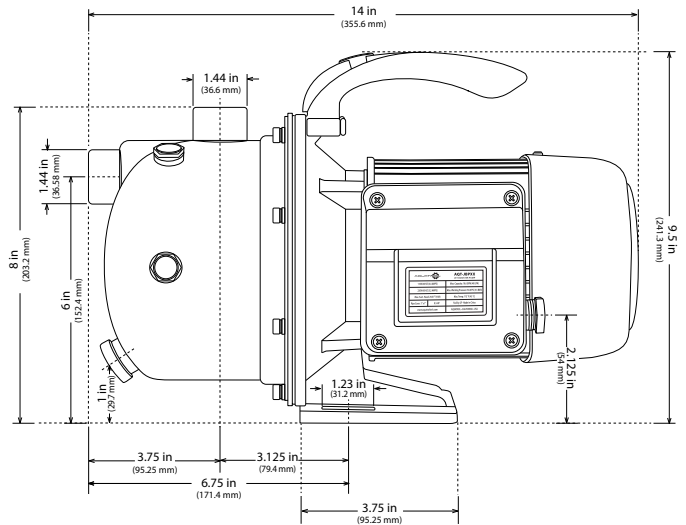

LIT-AQT-JBP-DS 08/21/20



Distributed by: